



## FEATURES

- NXP i.MX6 Application Processor with Long Life Cycle Support
- Support Up to Two Gigabit Ethernet Ports, with 802.3af PoE Option
- RS232, RS422/RS485 and CAN Bus Port Options
- On-board WiFi Module and Bluetooth 4.1 BLE
- Support Android 6.0.1, Debian Linux and Yocto Embedded Linux
- Slim Vent-hole Free Dustproof Fanless Aluminum Enclosure

The BIS-2230 is a small form factor fanless embedded PC based on INXP i.MX6 application processor. The system supports up to two Gigabit Ethernet ports and Power over Ethernet (PoE) option. The rich I/Os and slim design of this fanless computer fits perfectly for digital signage, kiosk, network security, IoT gateway and other industrial computer applications.

## SPECIFICATIONS

### SYSTEM

<b>Processor</b>	NXP i.MX6 1GHz Dual Lite or Quad-core
<b>Platform</b>	ARM Cortex A9
<b>Memory</b>	On-board 1GB DDR3
<b>Storage</b>	On-board iNAND Flash (8GB Default), 1 x Micro SD Slot
<b>OS</b>	Support Android 6.0.1, Debian Linux and Yocto Embedded Linux

### I/O INTERFACE

<b>Audio</b>	Internal Line-out, MIC-in, Headphone, Speaker Out Headers
<b>Display Interface</b>	1 x Micro HDMI
<b>Watchdog Timer</b>	Built-in
<b>I/O Ports</b>	1 x RS232/RS485/CAN 2 x GPIO Via Terminal Block 2 x USB 2.0 Type A 1 x Mini-USB OTG 2 x Internal USB 2.0 Header
<b>Expansion</b>	1 x 40 pin Internal Connector with PCIe x1 for 2nd Ethernet, GPIO, Front Panel Control, PoE Power Input

### POWER

<b>Power Input</b>	5V DC, PoE or 9V - 36V DC (Dual NIC Version)
--------------------	--

### COMMUNICATIONS

<b>Ethernet</b>	2 x Gigabit Ethernet, RJ45, One Support 802.3af PoE Power Input ( <b>Optional PoE Module</b> )
<b>Wireless</b>	On-board WiFi / BT Module 802.11 b/g/n + BLE 4.1 with <b>External Antenna Connector Option</b>

### MECHANICAL

<b>Enclosure Material</b>	Aluminum
<b>Enclosure Color</b>	Black
<b>Dimensions</b>	170 x 124 x 39mm (6.7" x 4.9" x 1.54")
<b>Mounting Option</b>	Support 75 x 75mm VESA Mount, or DIN-Rail Mount with <b>Optional Bracket</b>
<b>Cooling</b>	Fanless

### ENVIRONMENTAL

<b>Temperature:</b>	
- <b>Operation</b>	-20°C to 60°C (-28°F to 140°F)
- <b>Storage</b>	-40°C to 85°C (-40°F to 185°F)
<b>Humidity</b>	10% to 95% @ 40°C Non-condensing

## SYSTEM LAYOUT

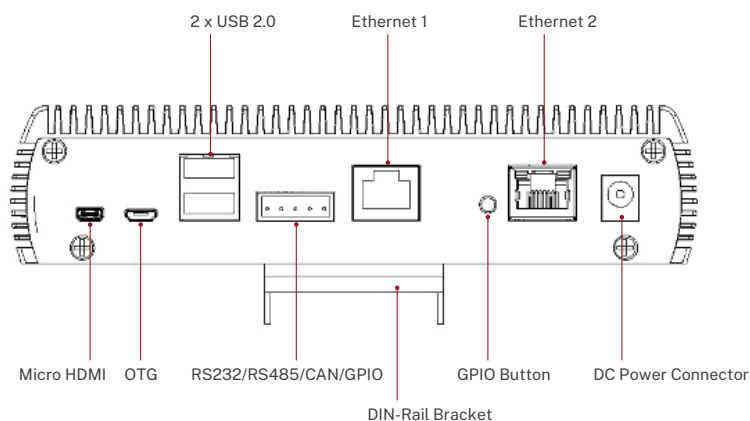

## PRODUCT DIMENSIONS

Unit: mm

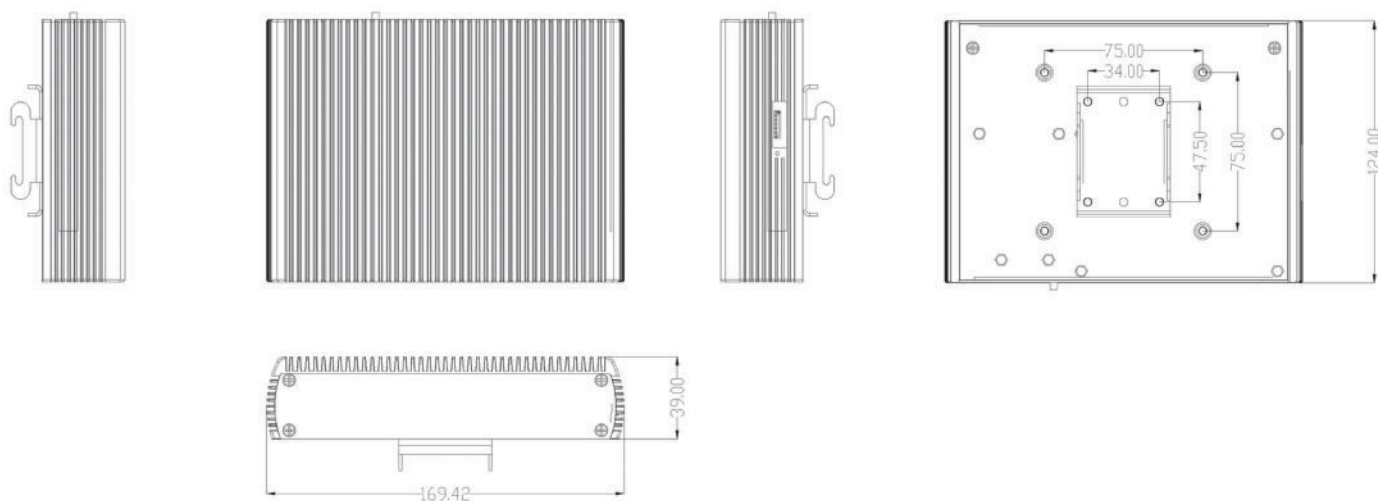

## ORDER INFORMATION

Part No.	Description
BIS-2230-DLS	Fanless PC with i.MX6 DL Processor, Single GbE, 5V DC Power Input
BIS-2230-DLP	Fanless PC with i.MX6 DL Processor, Single GbE, POE Power Input
BIS-2230-DLT	Fanless PC with i.MX6 DL Processor, Dual GbE, DC Power Input
BIS-2230-QPT	Fanless PC with i.MX6 Q Processor, Dual GbE, DC Power Input
CBL-2230-DIN	DIN-Rail Mount Bracket